

LT-DMX-9813 DMX-SPI Signal Decoder Manual



Welcome to choose our DMX decoder, DMX-SPI signal decoder works to convert DMX512 digital signal to SPI (TTL)digital signal. It can control LED lights compatible with driving IC, and control every channel of the LED lights, realize the function of 0~100% dimming or editing all sorts of change effect.

DMX-SPI decoder are widely used in LED flashing word string light, LED dot light, SMD strip, LED digital tubes, LED wall light, LED pixel screen, Hi-power spotlight, flood light, etc.

1. Product Parameter:

LT-DMX-9813	
Input Voltage	DC5V~DC24V
Input Signal	DMX512
Output Signal	P9813 Driving IC
Decoding Channels	512 Channels/Unit
Output Grey Scale	256 Levels/CH (8Bit/CH)
DMX512 Connector	XLR-3, Green Terminal
Product Dimension	L125×W52×H40mm
Package Size	L135×W70×H50mm
Working Temperature	-30°C~65°C
Weight (G.W.)	300g

2. Configuration Diagram:

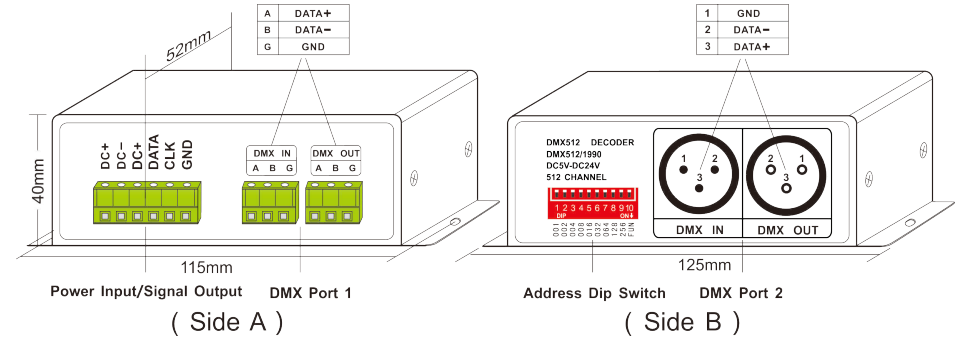

3. Output Port Definition:

No.	Silk Screen	Function
1	DC+	DC5V-24V LED power Supply Input
	DC-	
2	DC+	LED Power Supply Anode
	DATA	Data Cable
	CLK	Clock Cable
	GND	Ground Wire(DC-)

4. How to Set DMX Address via Dip Switch:

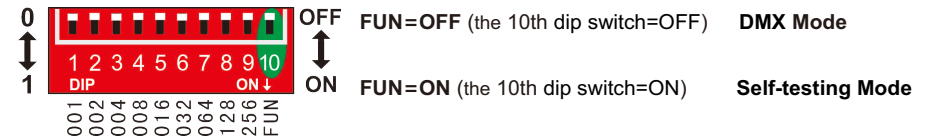

4.1 DMX Mode:

FUN=OFF (the 10th dip switch=OFF) **DMX Mode**

DMX address value=the total value of (1-9), to get the place value when in "on" position, otherwise will be 0.

E.g.1: Set Initial Address To 32.

E.g.2: Set Initial Address To 37.

E.g.3: Set Initial Address To 178.

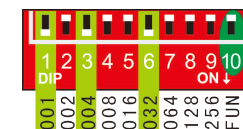
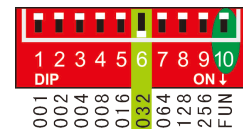

$001+004+032=37$

$002+016+032+128=178$

* When Dip switch 1-9 are OFF, the defaulted initial DMX address is 1.

2) Testing Function:

FUN=ON (the 10th dip switch = ON) Self-testing Mode

Dip Switch	1-9=off	1=on	2=on	3=on	4=on	5=on	6=on	7=on	8=on	9=on
Self-test Function	Static Black	Static Red	Static Green	Static Blue	Static Yellow	Static Purple	Static Cyan	Static White	7 Colors Jumping	7 Colors Smooth



Static Red
Static Blue
Static Purple
Static White
Static Green
Static Yellow
Static Cyan
7 Colors Jumping
7 Colors Smooth

For changing effects (Dip Switch 8/9=on):
DIP switch 1-7 is used to realize 7 speed levels. (7=on, the fastest level)

[Attn] When several dip switches are on, subjected to the highest switch value.
As the figure above shows, the effect will be 7 colors smooth at 7 speed level.

5. Configuration Diagram:

1) LED digital strip physical conjunction diagram

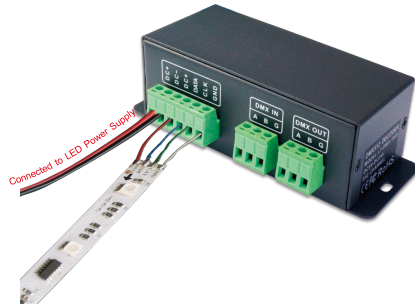

2) LED Wall washer conjunction diagram

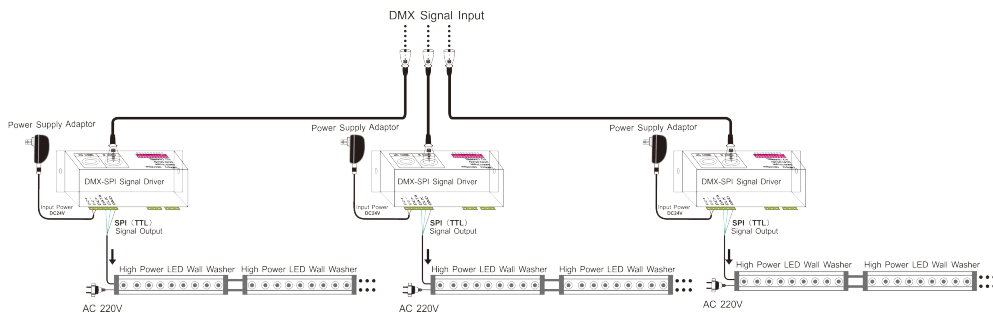

3) LED Digital Strip Conjunction Diagram.

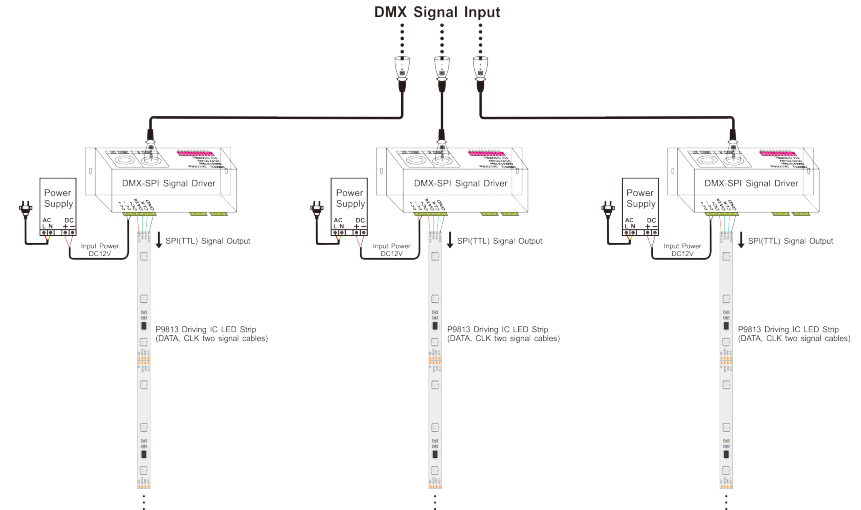

7. Attention

- 1) The product shall be installed and serviced by a qualified person.
- 2) This product is non-waterproof. Please avoid the sun and rain. When installed outdoors please ensure it is mounted in a water proof enclosure.
- 3) Good heat dissipation will prolong the working life of the controller. Please ensure good ventilation.
- 4) Please check if the output voltage of any LED power supplies used comply with the working voltage of the product.
- 5) Please ensure that adequate sized cable is used from the controller to the LED lights to carry the current. Please also ensure that the cable is secured tightly in the connector.
- 6) Ensure all wire connections and polarities are correct before applying power to avoid any damages to the LED lights.
- 7) If a fault occurs please return the product to your supplier. Do not attempt to fix this product by yourself.

8. Warranty Agreement:

- 1) We provide lifelong technical assistance with this product:
 - A 5-year warranty is given from the date of purchase. The warranty is for free repair or replacement and covers manufacturing faults only.
 - For faults beyond the 5-year warranty we reserve the right to charge for time and parts.
 - 2) Warranty exclusions below:
 - Any man-made damages caused from improper operation, or connecting to excess voltage and overloading.
 - The product appears to have excessive physical damage.
 - Damage due to natural disasters and force majeure.
 - Warranty label, fragile label and unique barcode label have been damaged.
 - The product has been replaced by a brand new product.
 - 3) Repair or replacement as provided under this warranty is the exclusive remedy to the customer. LTECH shall not be liable for any incidental or consequential damages for breach of any stipulation in this warranty.
 - 4) Any amendment or adjustment to this warranty must be approved in writing by LTECH only.
- ★ This manual only applies to this model. Ltech reserves the right to make changes without prior notice.